



L U X U R Y C O O L

REFRIGERATION WITH STYLE.

LUXURY COOL REFRIGERATORS
High technology at low temperatures.





High performance and refined design

Smeg's Luxury Cool collection offers a range of high-end refrigerators that employ the most advanced technologies: impeccably efficient and low on energy consumption, they offer cutting-edge performance.

The materials have been carefully selected for their excellent technical, hygienic and qualitative properties. The satin-finish stainless steel exteriors have an elegant and refined design: clean, minimal lines turn the refrigerator into an interior design feature with a strong character, one that is able to blend in harmoniously to any kitchen space.

Available both as freestanding and built-in units, Smeg's Luxury Cool refrigerators are hand-crafted in Italy with the care and attention to detail that only a company with long-standing experience in refrigeration can guarantee.



FRESH DETAILS



TOUCH DISPLAY

Everything is under control. Just a glance at the digital display will allow you to view the temperature in each compartment of the refrigerator. Lightly touching the buttons provides access to numerous functions, allowing you to activate them and customise refrigerator operation to suit your needs. In addition, a message appears on the display in the event of malfunction to allow you to promptly correct the fault.

INTERNAL LIGHTING

Two series of elegant white LED lights illuminate the interior from above, whilst the cool compartment and the Multi-zone drawer, are equipped with dedicated spotlights. In addition to guaranteeing excellent levels of brightness, LEDs also offer long life and low power consumption.

ADJUSTABLE SHELVES

The milk goes here, vegetables there, cheese above there, eggs below... it's easy to decide where more space is needed: the convenient shelves can be adjusted to any height and can also be moved without having to remove them; they slide vertically along side runners.



STRONG VARIABLE FULCRUM HINGES

The hinges have a dual self-balancing movement that allows for optimum usage of the recess space as well as guaranteeing excellent stability and support for an unlimited number of door opening manoeuvres.



ANTI-BACTERIAL DRAWERS

The stainless steel used for the interiors is mechanically treated in order to achieve a perfectly uniform surface that inhibits the spread of bacteria. The absence of sharp corners and gaps makes cleaning the drawers very easy, eliminating places where crumbs and food remnants would be difficult to reach.

STORAGE BELOW ZERO



MULTI-ZONE

Refrigerator, 0° zone or freezer: just select the desired menu function to change the temperature of the lower compartment in the refrigerator. This makes managing the storage environments extremely flexible, above all in the event of installations that require several units placed side-by-side.

COOLING BOTTLES

To rapidly cool bottles, just place them in the multi-zone drawer and activate the freezer function. You can also set a timer for this operation, from 1 to 45 minutes, after which time an alarm will sound to advise you that optimum temperature has been reached. Once you've removed the bottle, just press the Alarm button to deactivate the alarm. Then all you need to do is raise your glass for a toast.

PURE WATER, ICE AT THE READY

Immediately available ice cubes, in two different sizes, made automatically from water purified by the built-in filtering system. Once made, the ice cubes are sent to the ice compartment in the multi-zone drawer.



TOTAL NO-FROST

This is a fully automatic system that eliminates the need to defrost the refrigerator, the 0° compartment and the freezer. It is an extremely practical solution that reduces refrigerator maintenance to a minimum. Thanks to rapid cooling, the system also means the correct temperature is quickly restored each time the door is opened.

MULTI-FLOW

Independent ventilation in each refrigerator compartment and even distribution of the cool air flow ensure uniform temperatures, which are essential for optimum food preservation.

FOOD PRESERVATION UNDER CONTROL

Thanks to an accurate detection system, the refrigerator warns you of any anomalies, such as a drawer left open, by sounding an alarm. This guarantees optimum food preservation.

SHOPPING FUNCTION

When you arrive home with your shopping, you place food in the refrigerator that is usually at a higher temperature than the food already in there. The Shopping function lessens the impact of this temperature difference by increasing the speed of the cooling and freezing process, improving food preservation. This function is also very useful when you know that the refrigerator will be opened more often usual, for example when you are preparing an elaborate meal, as it prevents the internal temperature from getting too high.

SABBATH FUNCTION

This function makes it easier to observe the practices of the Jewish religion. Temperature indications, ice production and internal lighting are deactivated, whilst the refrigerator continues to function.

PROFESSIONAL PERFORMANCE





RF396RSIX

**Combi Fridge-Freezer, stainless steel, 90 cm.
A+ energy efficiency class**

Total gross capacity: 530 Litres
Completely frost-free
Touch display functions: Holiday, Rapid freezing, Rapid cooling, Multi-zone, ECO, Key lock (child lock), Temperature alarm signal and display warning
Multi-zone compartment
2 compressors
LED internal lighting
Variable fulcrum hinges on the right

Refrigerator:

Usable volume of fresh foods compartment: 417 Litres
Multi-flow
3 adjustable glass shelves
1 Life Plus 0°C anti-bacterial sliding drawer
1 fruit and veg anti-bacterial sliding drawer
1 glass shelf covering fruit and veg compartment
Inside door:
2 adjustable shelves
1 one shelf for bottles with metal wire

Freezer:

Usable volume of frozen foods compartment: 107 Litres
Fast freeze area
2 drawers
Automatic ice maker (only if connected to the mains water system)

Also available:

RF396LSIX - Stainless steel, hinges on the left

Optional extras:

REFLK6090 - grille and plinth kit for combining Wine Cellar WF366
+ Refrigerator RF396
REFLKA1 - Joint kit for combining Wine Cellar WF366
+ Refrigerator RF396 and RF376

The technical drawing for installation can be found at the end of the catalogue.



RF376RSIX

Combi Fridge-Freezer, stainless steel, 75 cm.

A+ energy efficiency class

Total gross capacity: 425 Litres
Completely frost-free
Touch display functions: Holiday, Rapid freezing, Rapid cooling, Multi-zone, ECO, Key lock (child lock), Temperature alarm signal and display warning
Multi-zone compartment
2 compressors
LED internal lighting
Variable fulcrum hinges on the right

Refrigerator:

Usable volume of fresh foods compartment: 327 Litres
Multi-flow
3 adjustable glass shelves
1 Life Plus 0°C anti-bacterial sliding drawer
1 fruit and veg anti-bacterial sliding drawer
1 glass shelf covering fruit and veg compartment
Inside door:
2 adjustable shelves
1 one shelf for bottles with metal wire

Freezer:

Usable volume of frozen foods compartment: 85 Litres
Fast freeze area
2 drawers
Automatic ice maker (only if connected to the mains water system)

Also available:

RF376LSIX - Stainless steel, hinges on the left

Optional extras:

REFLK6075 - grille and plinth kit for combining Wine Cellar WF366
+ Refrigerator RF376

REFLKA1 - Joint kit for combining Wine Cellar WF366
+ Refrigerator RF396 and RF376

The technical drawing for installation can be found at the end of the catalogue.



RI96RSI

Built-in combi Fridge-Freezer, 90 cm.

A+ energy efficiency class

Total gross capacity: 530 Litres
Completely frost-free
Touch display functions: Holiday, Rapid freezing, Rapid cooling, Multi-zone, ECO, Key lock (child lock), Temperature alarm signal and display warning
Multi-zone compartment
2 compressors
LED internal lighting
Self-supporting variable fulcrum hinges on the right

Refrigerator:

Usable volume of fresh foods compartment: 417 Litres
Multi-flow
3 adjustable glass shelves
1 Life Plus 0°C anti-bacterial sliding drawer
1 fruit and veg anti-bacterial sliding drawer
1 glass shelf covering fruit and veg compartment
Inside door:
2 adjustable shelves
1 one shelf for bottles with metal wire

Freezer:

Usable volume of frozen foods compartment: 107 Litres
2 drawers
Automatic ice maker (only if connected to the mains water system)

Also available:

RI96LSI - Hinges on the left

Optional extras:

REFLKB1 - Joint kit for combining Wine Cellar WI66 + Refrigerator RI96.

The technical drawing for installation can be found at the end of the catalogue.



RI76RSI

Built-in combi Fridge-Freezer, 75 cm.

A+ energy efficiency class

Total gross capacity: 425 Litres
Completely frost-free
Touch display functions: Holiday, Rapid freezing, Rapid cooling, Multi-zone, ECO, Key lock (child lock), Temperature alarm signal and display warning
Multi-zone compartment
2 compressors
LED internal lighting
Self-supporting variable fulcrum hinges on the right

Refrigerator:

Usable volume of fresh foods compartment: 327 Litres
Multi-flow
3 adjustable glass shelves
1 Life Plus 0°C anti-bacterial sliding drawer
1 fruit and veg anti-bacterial sliding drawer
1 glass shelf covering fruit and veg compartment
Inside door:
2 adjustable shelves
1 one shelf for bottles with metal wire

Freezer:

Usable volume of frozen foods compartment: 85 Litres
2 drawers
Automatic ice maker (only if connected to the mains water system)

Also available:

RI76LSI - Hinges on the left

Optional extras:

REFLKB1 - Joint kit for combining Wine Cellar WI66 + Refrigerator RI76

The technical drawing for installation can be found at the end of the catalogue.

LUXURY COOL WINE CELLARS

A toast at the perfect temperature.





Where the finest wines feel at home

The luxury of having a wine cellar in your own home means that your favourite wines are always ready for tasting. Each wine has its own ideal temperature and with Luxury Cool wine cellars you can precisely set each one: this means that all your wines will be at their best, from Amarone to Pinot Grigio.

With its elegant design, the Luxury Cool collection wine cellar is a refined interior design feature, made from precious materials such as stainless steel for the outside and wood for the internal shelves.

It can be combined with both freestanding and built-in refrigerators to complete the home in style.



CONNOISSEURS RESERVE

A PLACE FOR EACH WINE

The wine cellar has a total capacity of 54 bottles, 36 on the upper shelves and 18 on the lower ones. Each shelf slides out and can easily be removed for cleaning.

TELESCOPIC SHELF GUIDES

Each shelf rests on special guides that run on wheels, allowing the shelf to be easily pulled out for comfortable access to the bottles.

QUADRUPLE GLASS

The door has 4 panels of bronzed glass, offering the highest levels of protection against UV rays and sudden changes in temperature.



2 INDEPENDENT ZONES

Two independent compartments, with adjustable temperature from 4 to 18 degrees, allows you to maintain the ideal temperature for different types of wine.

FINE WINES

The lower compartment of the wine cellar is dedicated to ageing the finest red wines. It has an accurate temperature control system and humidity level control system with three settings: low, average and high.

LIGHTS

Each shelf is equipped with an LED lighting system that allows you to see each bottle clearly. The Fine Wines compartment has two independent LED lights, like the Multi-zone drawer.



MULTI-ZONE

RAPID COOLING

An unexpected toast? You can rapidly cool bottles by simply placing them in the Multi-zone drawer and activating the dedicated function: they will be ready after a very short time, and an alarm will tell you when they have reached optimum temperature.



MULTI-ZONE DRAWER

In order to manage food storage methods in the best possible way, the temperature of the Multi-zone compartment can be fully adjusted using the display. It can be used as a refrigerator, freezer or 0° compartment: extreme flexibility to satisfy all needs.



AMBIENT TEMPERATURE SENSOR

Even if the ambient temperature changes suddenly, your wines won't be affected: a sensor automatically activates a system that ensures the inside of the wine cellar is maintained at optimum temperature.

NO VIBRATIONS

Wines are extremely sensitive: in order to protect them against the damaging effects of vibrations, the wine cellar has a system that reduces compressor vibration to a minimum. In addition, each shelf has a soft sliding system to protect the bottles from knocks or rapid movements.



WF366RDX

Wine cellar, stainless steel and glass, 60 cm.

A energy efficiency class

Door in anti-UV glass: 4 sheets of glass
Touch display functions: Holiday Multi-Zone, Shopping Multi-Zone, Cooling Timer, Multi-zone options, Key lock (child lock), Sabbath mode, Showroom mode, Temperature alarm and visual warning
Automatic defrost
LED internal lighting
Variable fulcrum hinges on the right

Upper Wine Cellar compartment:

Usable volume: 150 Litres
Capacity: 36 bottles
Adjustable temperature from +4°C to +18°C
6 removable wooden shelves that slide on telescopic guides

Lower Wine Cellar Compartment:

Usable volume: 78 Litres
Capacity: 18 bottles
Adjustable temperature from +4°C to +18°C
Humidity level adjustment with 3 settings: low, average, high
3 removable wooden shelves that slide on telescopic guides

MULTI-ZONE compartment:

FROST-FREE
Usable volume: 59 Litres
2 drawers
Adjustable temperature as Freezer compartment: between -18°C and -22°C
Adjustable temperature as Refrigerator compartment: between +2°C and +8°C
Adjustable temperature as 0°C compartment: between -2°C and +2°C

Also available:

WF366LDX - Hinges on the left

Optional extras:

REFLK6090 - grille and plinth kit for combining Wine Cellar WF366 + Refrigerator RF396
REFLK6075 - grille and plinth kit for combining Wine Cellar WF366 + Refrigerator RF376
REFLKA1 - Joint kit for combining Wine Cellar WF366 + Refrigerator RF396 and RF376

The technical drawing for installation can be found at the end of the catalogue.



WI66RS

Built-in wine cellar, 60 cm.

A energy efficiency class

Door in anti-UV glass: 4 sheets of glass
Touch display functions: Holiday Multi-Zone, Shopping Multi-Zone, Cooling Timer, Multi-zone options, Key lock (child lock), Sabbath mode, Showroom mode, Temperature alarm and visual warning
Automatic defrost
LED internal lighting
Self-supporting variable fulcrum hinges on the right

Upper Wine Cellar compartment:

Usable volume: 150 Litres
Capacity: 36 bottles
Adjustable temperature from +10°C to +18°C
6 removable wooden shelves that slide on telescopic guides

Lower Wine Cellar Compartment:

Usable volume: 78 Litres
Capacity: 18 bottles
Adjustable temperature from +4°C to +12°C
Humidity level adjustment with 3 settings: low, average, high
3 removable wooden shelves that slide on telescopic guides

MULTI-ZONE drawer:

FROST-FREE
Usable volume: 59 Litres
2 drawers
Adjustable temperature as Freezer compartment: between -18°C and -22°C
Adjustable temperature as Refrigerator compartment: between +2°C and +8°C
Adjustable temperature as 0°C compartment: between -2°C and +2°C

Also available:

WI66LS - Hinges on the left

Optional:

REFLKB1 - Joint kit for combining Wine Cellar WI66 + Refrigerator RI76 or RI96

The technical drawing for installation can be found at the end of the catalogue.

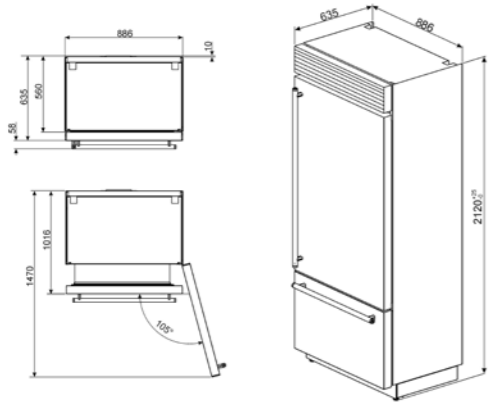

RF396RSIX

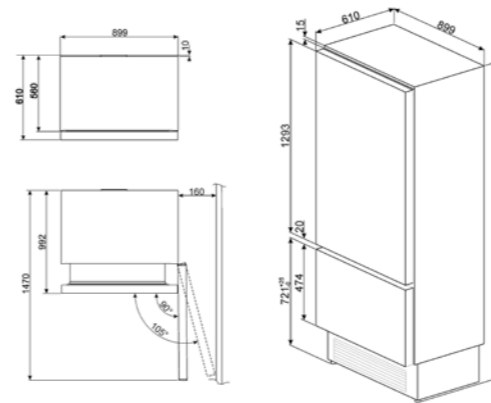

RI76RSI

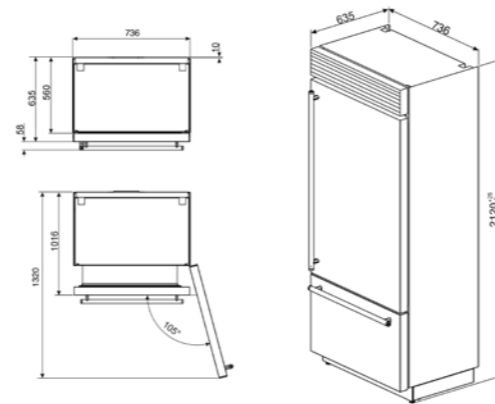

RF376RSIX

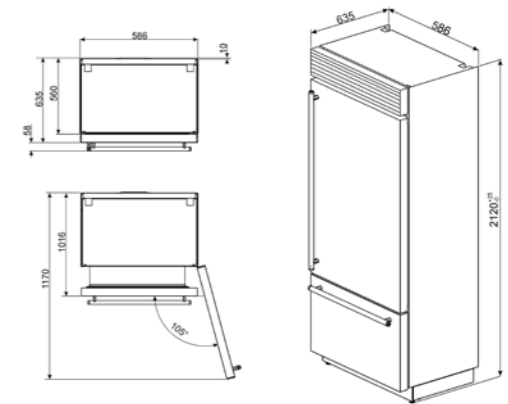

WF366RDX

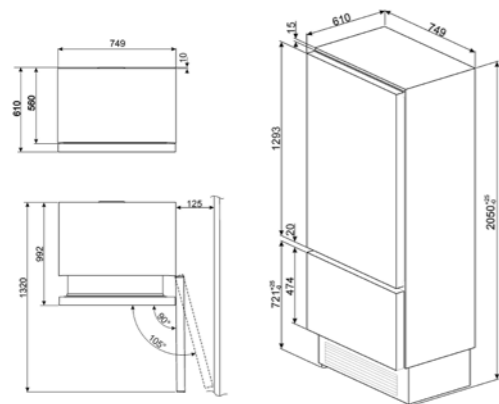

RI96RSI

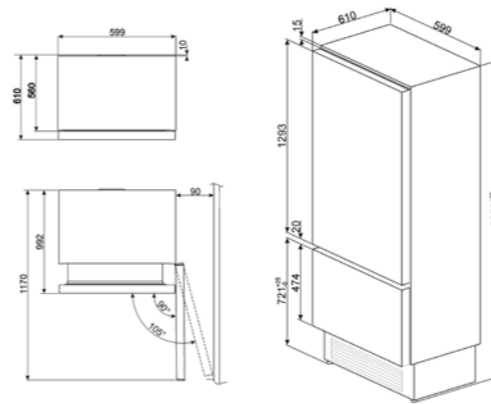

WI66RS

Smeg S.p.A. reserves the right to modify its products without notification.
The illustrations, data and descriptions in this catalogue are not binding and are purely illustrative.
Covering panels shown with the products are not provided, they are added for photographic purposes only.
For correct installation, it is absolutely imperative to follow the relevant technical instructions for each appliance.



Smeg S.p.A.
Via Leonardo da Vinci, 4 Guastalla (RE)42016
+39 0522 8211 www.smeg.it