

SKSDW2402P | Sliding hinge dishwasher

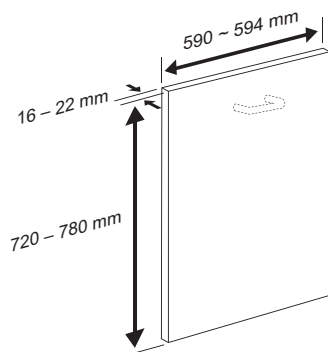

INSTALLATION

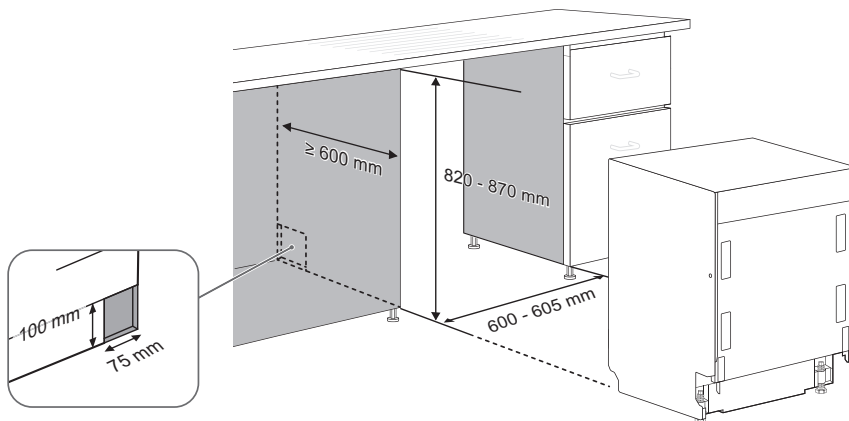

$2.5 \text{ kg} \leq \text{▲} \leq 11 \text{ kg}$

$\text{▲} 8 \text{ kg} \leq \text{▲} \leq 11 \text{ kg} \text{▲}$

SKSDW2402P	EAN: 8806098608034
Covered	14
Inverter Direct Drive Motor	●
Wi-Fi enabled for SmartThinQ® control with iOS/Android app	●
TrueSteam™	●
QuadWash™	●
Programs	(10) Auto, Deep clean, Delicate, Refresh, Eco, Boost, Download cycle, Machine Clean, Rinse, Express
Options	(8) Dual zone, Half load, Energy saver, Steam, High temp, Extra Dry, Delayed Start, Control Lock
Aqua-Stop	●
Drying type	Auto Open Condensation / Drying
Vario Plus washing system	●
3° height-adjustable basket	●
Auto opening door	●
Running time indicator	●
Salt refill indicator	●
Rinse refill indicator	●
Energy consumption and noise levels	
Energy efficiency class	D
Eco Program sound Level	43 dBA
Water consumption per cycle	9.5 L
Energy consumption per cycle	0.849 kWh
Energy consumption/year	310 kWh
Standard cycle time (ECO)	193 min.
Express cycle time	56 min.
Boost cycle time	78 min. (0,84 kWh/ 9,6L)
Technical Specifications	
Required power supply	220 ~ 240V, 50Hz
Dimensions (WxDxH)	598x554x815 mm (23"x21"32")
Height of niche	815 ~ 875 mm (32" ~ 34")
Adjustable feet	60 mm (2")
Net weight	40 kg
Door panel technical specifications	
Width	590 mm - 594 mm (23.2" - 23.4")
Height	720 mm - 780 mm (28.3" - 30")
Thickness	16 mm - 22 mm (0,6" - 0.8")
Hinge capacity	2,5 kg - 11 kg