

# SKSUD2402E | Undercounter convertible refrigerator

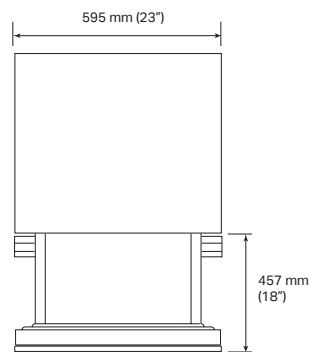

**TOP VIEW**

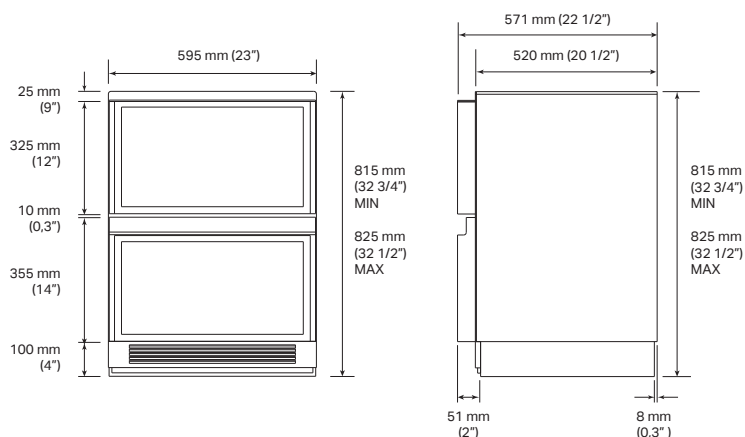

**FRONT VIEW**

**SIDE VIEW**

## CUSTOM PANELS

### Paneling options

#### SKSUK240DS: Stainless steel panel kit

The appliance can be paneled with the optional SKS stainless steel door kit.

The kit includes one panel for the upper drawer and one of a different height for the lower drawer.

### Custom paneling

The appliance is designed to be customized with custom panels to match the kitchen cabinetry.

For custom panel dimensions, please refer to the diagram and specifications below:

Upper drawer panel - 595 mm x 346.5 mm

Lower drawer panel - 595 mm x 330.5 mm

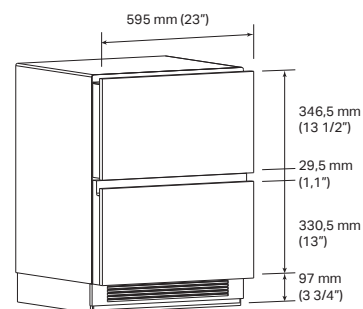

## INTERNAL DRAWER DIMENSIONS

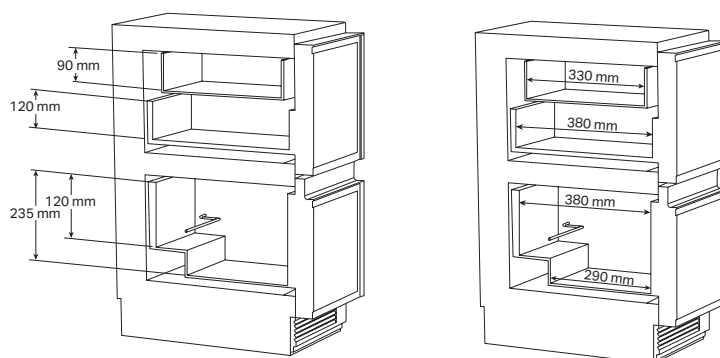

<b>SKSUD2402E</b>	EAN: 8806091740946
Door type	Panel ready
Internal finish	Stainless steel
<b>Energy Label</b>	
Energy efficiency class	E
Net total capacity	89 L
Net refrigerator capacity	43
Net freezer capacity	46
Maximum sound level	< 37 dbA Max
ENERGY STAR® Qualified	●
Yearly total energy consumption (kW/h)	109
Average power consumption (W)	15
Estimated maximum power consumption (W)	49
<b>General properties</b>	
No-Frost	●
Smart Inverter compressor	●
Wi-Fi enabled for SmartThinQ® control with iOS/Android app	●
Automatic Adaptive Defrost	●
Modes	Freezer (-23 C° to -15 C°), Meat (-3 C°), Seafood (1 C°), Bar (1 C°), Refrigerator (2°C to 7 C°), Pantry (10 C°)
Speed Freeze	●
True-View® Lighting	●
Digital Controls w/ White LED Display	●
Operating temperatures	Upper drawer: from -3°C to 10°C Lower drawer: from -23°C to 10°C
<b>Installation</b>	
Reversible Door	●
Four Point Front Adjustable with 4 Wheels	●
Attachment method to cabinetry	Top with no visible screws
Front Serviceable	●
Anti-tip Bracket Included	●
<b>Technical Specifications</b>	
Overall width	595 mm (23")
Overall height	815 mm (32 1/2") MIN ~ 825 mm (32 1/2") MAX
Overall depth	571 mm (22 1/2")
Net weight	64 kg
Shipping weight	69 kg
Max packaged product dimensions	970x650x650 mm (38"x25"x25")
<b>Accessories</b>	
Steel doors kit	SKSUK240DS

# SKSUD2402E | Undercounter convertible refrigerator

## INSTALLATION NOTES

### Electrical specifications

A 230V, 50Hz power supply is required. It is recommended to provide a three-pole outlet recessed in the wall and properly grounded, equipped with a dedicated circuit.

### Visible area

The indicated zone (102 mm) will be visible once the refrigerator doors are opened; plan to finish this area on both sides.

### ATTENTION

If you plan to place the electrical connection not on the back of the cabinet in which the product is installed, but outside of it, you can install the product flush front in a cabinet with a reduced depth of 605 mm.

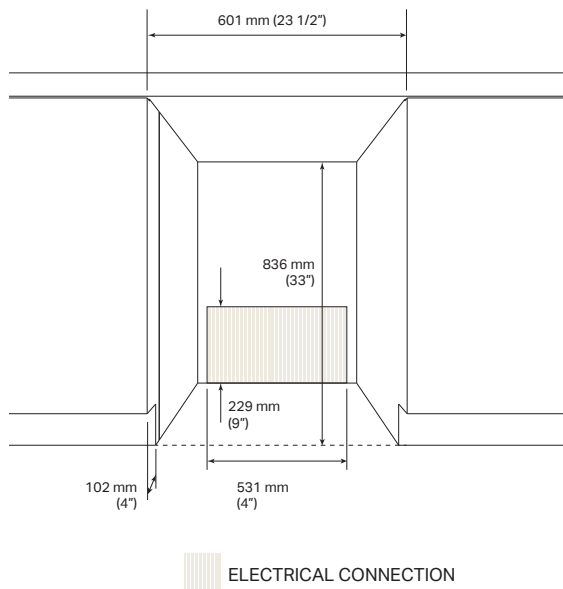

## Flush or extended installation

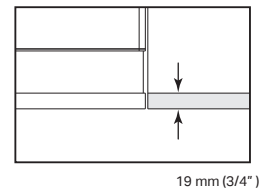
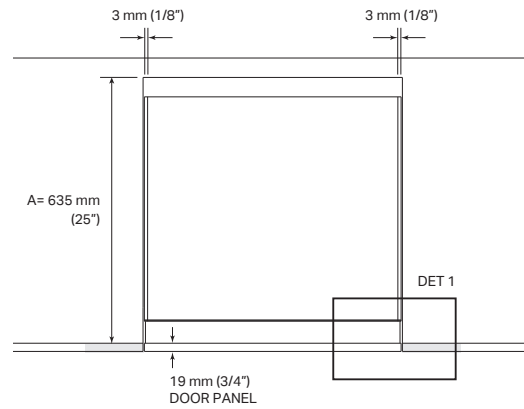

**TOP VIEW**  
FLUSH INSTALLATION

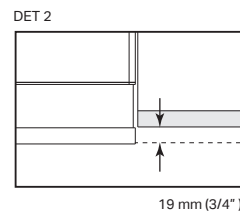
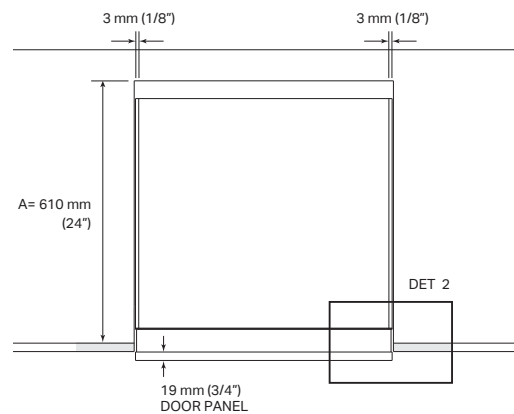

**TOP VIEW**  
EXTENDED INSTALLATION

## **INSTALLATION NOTES**

### **Door clearances with flush installation**

The installation must provide clearances from the furniture in front.

The values indicated below refer to the mobile edge outside the door including the aesthetic panel, with drawer fully extracted:

Lower drawer: 400 mm

Upper drawer: 330 mm

### **UPPER DRAWER OPENING**

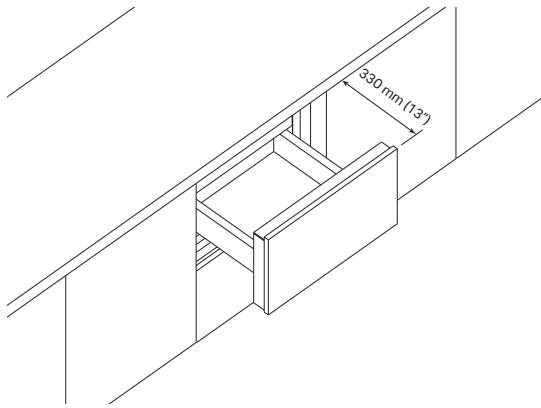

### **LOWER DRAWER OPENING**

