

90cm Series 7 Integrated French Door Refrigerator Freezer

Series 7 | Integrated

Panel Ready



This large capacity refrigerator with bottom freezer seamlessly integrates into your kitchen, fitting flush into your cabinetry.

- ActiveSmart™ technology helps keep food fresher for longer by constantly maintaining the ideal temperature
- Customise with your own kitchen cabinetry or purchase our stainless steel door panel accessory

- Spacious bottom freezer with full extension drawer gives easy access to frozen goods.

DIMENSIONS

Height	1798 mm
Width	896 mm
Depth	610 mm

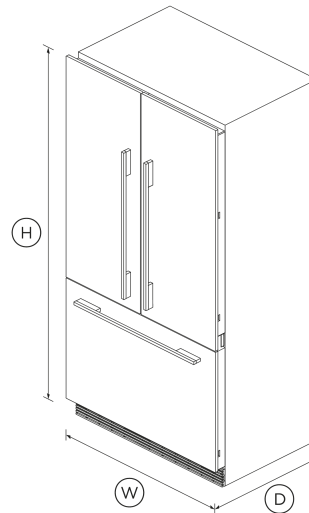

FEATURES & BENEFITS

ACTIVESMART™ FOODCARE

ActiveSmart™ Foodcare learns how you live. It's technology which understands how you use your refrigerator and adjusts temperature, airflow and humidity inside to help keep food fresher for longer.

Flexible storage

Designed to make it simple for you to store, access and remove food. Storage bins give you full access inside when they're pulled open and can be easily removed to clean. Our flexible shelving also gives you more storage options.

Easy cleaning

Secure, spill-safe glass shelves easily capture any drips or leaks, and can be easily removed for fast and easy cleaning.

Beautiful Lighting

LED lighting illuminates the interior with a crisp, clean glow for enhanced visibility. Our energy saving LEDs use less power than comparable halogen lights.

Easy installation

Our integrated products are easy to install, whether you are renovating your kitchen or designing a new one. Adjustable front and rear feet allow for uneven floors alongside adjustable door panels that can be customised to match your kitchen.

SPECIFICATIONS

Accessories (sold separately)

Door panel set stainless steel	RD90A
Handle kit Classic	AHCLR90A
Handle kit Contemporary round, aluminium	AHS-ASBI-A
Handle kit Contemporary square fine, aluminium	AHD5RD90A
Handle kit Contemporary square fine, black	AHD5RD90AB

Capacity

Total gross capacity	525 L
Volume freezer	145 L
Volume refrigerator	331 L

Consumption

Energy rating	E
Energy usage	304kWh/year

Features

Adjustable door shelves	6
Adjustable glass cantilevered shelves	•
Adjustable glass shelves	3
Covered door shelves	2
Door alarm	•
Fruit and vegetable bins	2
Gallon door shelves	1
LED lighting	•
SmartTouch control panel	•
Soft close doors	•
Spill proof removable bins	•
Stackable bottle holders	4

Freezer Features

Bottle chill	•
Door alarm	•
Ice trays	1
Large plastic bins	•
LED bin lighting	•
Slide Out Pastry Tray	•
Small plastic bins	•

Performance

ActiveSmart™ Foodcare	•
Adaptive defrost	•
Frost free freezer	•
Humidity control system	•
Inverter controlled compressor	•
Sabbath mode	•

Power requirements

Supply voltage	230 V
----------------	-------

Product dimensions

Depth	610 mm
Height	1798 mm
Width	896 mm

Variable Temp Compartment

Bottle chill mode	•
-------------------	---

SKU	26655
-----	-------

The product dimensions and specifications in this page apply to the specific product and model. Under our policy of continuous improvement, these dimensions and specifications may change at any time. You should therefore check with Fisher & Paykel's Customer Care Centre to ensure this page correctly describes the model currently available. © Fisher & Paykel Appliances Ltd 2020

Other product downloads available at fisherpaykel.com

- [↓](#) 2D-DWG Integrated Refrigeration - K08 Hinge
- [↓](#) 2D-DWG Integrated French Door Fridge Freezer
- [↓](#) 2D-DXF Integrated Refrigeration - K08 Hinge
- [↓](#) 2D-DXF Integrated French Door Fridge Freezer
- [↓](#) Archicad Integrated French Door Fridge Freezer
- [↓](#) Data Sheet Integrated French Door Fridge Freezer
- [↓](#) Declaration of Conformity
- [↓](#) Energy Label Integrated French Door Refrigerator Freezer
- [↓](#) Service & Warranty
- [↓](#) Installationsvejledning DA
- [↓](#) Installatiehandleiding DUT
- [↓](#) Asennusopas FI
- [↓](#) Guide d'installation FR
- [↓](#) Installationsanleitung DEU
- [↓](#)  HE
- [↓](#) Guida d'installazione IT
- [↓](#) Installasjonsveiledning NOR
- [↓](#) Guía de instalación SP
- [↓](#) Installationsguide SWE
- [↓](#) Product Fiche
- [↓](#) Planning Guide Integrated French Door Fridge Freezer
- [↓](#) Revit Integrated French Door Fridge Freezer
- [↓](#) Sketchup Integrated French Door Fridge Freezer

Where applicable:

All appliances use energy, and energy usage typically generates carbon emissions. **Fisher & Paykel Appliances' In-use Energy Carbon Emissions Estimate** indicates carbon emissions from a product's in-use energy. This is calculated either annually or per cycle, using the product's market-specific energy label energy consumption data multiplied by the carbon emissions factor for energy in your country or region.

Our In-use Energy Carbon Emissions Estimate is designed to assist customers in making informed purchasing decisions when comparing different Fisher & Paykel products. For example, a heat pump dryer typically has a lower In-use Energy Carbon Emissions Estimate than a vented dryer.



A PEACE OF MIND SALE
24 Hours 7 Days a Week Customer Support
T 08000886605 W www.fisherpaykel.com